

Specifications

Models		GS-2646	
Measurements		Metric	US
Working height maximum*		9.80 m	32 ft 1 in
A	Platform height maximum w/load sense	7.80 m	25 ft 6 in
B	1.16 m	3 ft 10 in	3 ft 5 in
C	2.26 m	7 ft 5 in	7 ft 5 in
	3.18 m	10 ft 5 in	10 ft 5 in
Slide-out platform extension deck		0.91 m	3 ft
D	1.15 m	3 ft 10 in	3 ft 10 in
Guardrail height		1.10 m	3 ft 7 in
Toeboard height		0.15 m	6 in
E	2.26 m	7 ft 5 in	7 ft
	1.68 m	5 ft 6 in	5 ft 1 in
F	2.41 m	7 ft 11 in	7 ft 11 in
	3.33 m	10 ft 11 in	10 ft 11 in
G	1.17 m	3 ft 10 in	3 ft 10 in
H	1.85 m	6 ft 1 in	6 ft 1 in
I	9.5 cm	3.75 in	3.75 in
J	1.9 cm	0.75 in	0.75 in

Productivity

Maximum platform occupancy (indoor/outdoor)	2/2	2/2
Lift capacity	454 kg	1,000 lbs
Lift capacity - extension deck	113 kg	250 lb
Drive speed - stowed	3.2 km/h	2 mph
Drive speed - raised	0.8 km/h	0.5 mph
Gradeability - stowed **	30%	30%
Turning radius - inside	zero	zero
Turning radius - outside	2.29 m	7 ft 6 in
Raise / lower speed	30 / 30 sec	30 / 30 sec
Controls	proportional	
Drive	dual front wheel	
Multiple disc brakes	dual rear wheel	
Tyres - solid non-marking	38 x 13 x 28 cm	15 x 5 x 11 in

Power

Power source	24 V DC (four 6 V 225 Ah batteries)	
Hydraulic system capacity	17 L	4.5 gal

Sound & Vibration Levels

Sound pressure level (ground workstation)	<70 dBA	<70 dBA
Sound pressure level (platform workstation)	<70 dBA	<70 dBA
Vibration	<2.5 m/s ²	<8 ft 2 in/s ²

Weight***

2,447 kg 5,395 lbs

Standards Compliance

EU Directives: 2006/42/EC - Machinery (harmonized standard EN280);
2004/108/EC (EMC); 2006/95/EC (LVD)

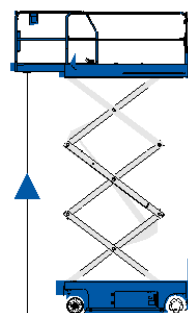
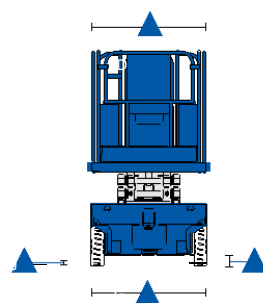
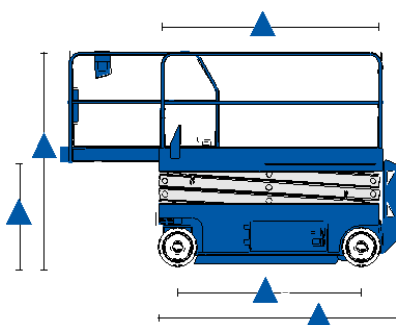

* The metric equivalent of working height adds 2 m to platform height.
** Gradeability applies to driving on slopes. See operator's manual for details regarding slope ratings.
*** Weight will vary depending on options and/or country standards.

Features

Standard Features	Easily Configured To Meet Your Needs	Options & Accessories
-------------------	--------------------------------------	-----------------------

Measurements

GS-2646

- 9.80 m (32 ft 1 in) working height
- Up to 454 kg (1,000 lbs) lift capacity

Productivity

- Folding rails with full height swing gate
- Smart Link™ control system (joystick, 2 lift speeds & 2 selectable proportional drive speeds, user-friendly diagnostics)
- Rear recessed charger receptacle
- Platform control with battery charge indicator
- On-board diagnostic system
- AC power to platform
- Lanyard attachment points
- Manual platform lowering valve
- Emergency stop at both platform and ground controls
- Rear wheel multiple disc brakes
- Front wheel hydraulic dynamic braking
- Manual hydraulic brake release
- Swing-out component trays
- Pothole guards
- Tilt level sensor with audible alarm
- Descent alarm
- Flashing LED beacons
- Electronic horn
- Hour meter
- Telematics-Ready Connector

Power

- 24 V DC battery pack
- Universal 20 amp smart charger

Platform

- 2.26 x 1.15 m (7 ft 5 in x 3 ft 9.3 in) steel platform
- 0.91 m (3 ft) extension deck

Power

- 24 V DC (four 6 V 225 Ah batteries)

Drive

- Dual front wheel drive

Tyres

- Solid non-marking

Options & Accessories

Productivity Options

- Air line to platform
- Power to platform: plug, socket, with optional Residual-current Circuit Breaker with Overcurrent protection
- Biodegradable hydraulic oil
- Track & Trace⁽¹⁾ (GPS unit providing machine location & operating information)
- Motion alarm
- Automotive horn

Power Options

- Maintenance-free batteries
- Low-temperature cut-out module

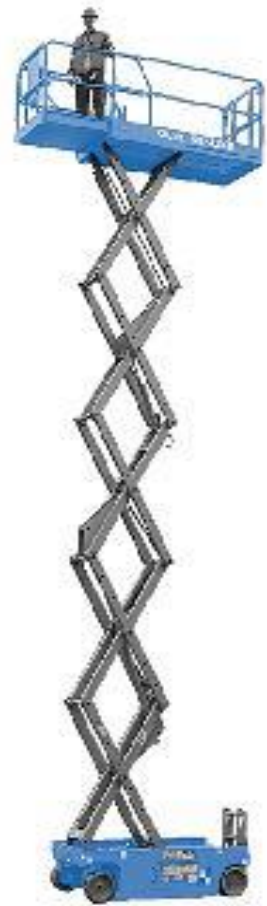

⁽¹⁾Includes a first 2 years subscription

United Kingdom and MESART

The Maltings, Wharf Road, Grantham NG31 6BH, T: +44 800 988 3739 (toll free), Fax +44 (0)1476 584334, Email AWP-InfoEurope@terex.com
Middle East, Southern Africa, Russia and Turkey, T: +971 4 399 0381, Email AWP-InfoME@terex.com Visit

www.genielift.com/en-gb/about-genie/locations to view our global locations list.

Worldwide Manufacturing And Distribution

Australia · Brazil · Caribbean · Central America · China · France · Germany · Italy · Japan · Korea · Mexico · Russia · Southeast Asia · Spain · Sweden · United Arab Emirates · United Kingdom · United States

Product specifications and prices are subject to change without notice or obligation. The photographs and/or drawings in this document are for illustrative purposes only. Refer to the appropriate Operator's Manual for instructions on the proper use of this equipment. Failure to follow the appropriate Operator's Manual when using our equipment or to otherwise act irresponsibly may result in serious injury or death. The only warranty applicable to our equipment is the standard written warranty applicable to the particular product and sale and we make no other warranty, express or implied. Products and services listed may be trademarks, service marks or trade names of Terex Corporation and/or their subsidiaries in the USA and many other countries. Genie is a registered trademark of Terex South Dakota, Inc. © 2019 Terex Corporation.

